



23001 Industrial Blvd, Rogers, MN 55374 / 1-866-527-7637  
[www.motoalliance.com](http://www.motoalliance.com)

## VIPER Winch Mount

MA11991

### John Deere Gator RSX 850i

Thank you for purchasing our VIPER winch mount. You now own a premium custom winch mount which allows you to use your winch with your UTV / SxS. Please note the following instructions and heed all warnings:

- Please use common sense when operating your UTV / SxS
- Read your Winch Operator Manual and all other operator manuals, including warning labels, before operating your UTV / SxS
- Be observant of moving parts causing entanglement; use extreme caution!

**SEVERE INJURY OR DEATH MAY RESULT IF YOU ARE NEGLIGENT.**

**MA11991  
John Deere RSX 850i Winch Mount**



**motoalliance**  
23001 Industrial Blvd  
Rogers, MN 55374  
866.527.7637

**Please verify that all hardware and parts are included in your package.**

**Kit Contents:**

Item	Description	QTY
1	MA11991 Mount Plate	1
2	3/8"-16 Serrated Flange Nut	6
3	3/8"-16 x 1" Serrated Flange Bolt	6

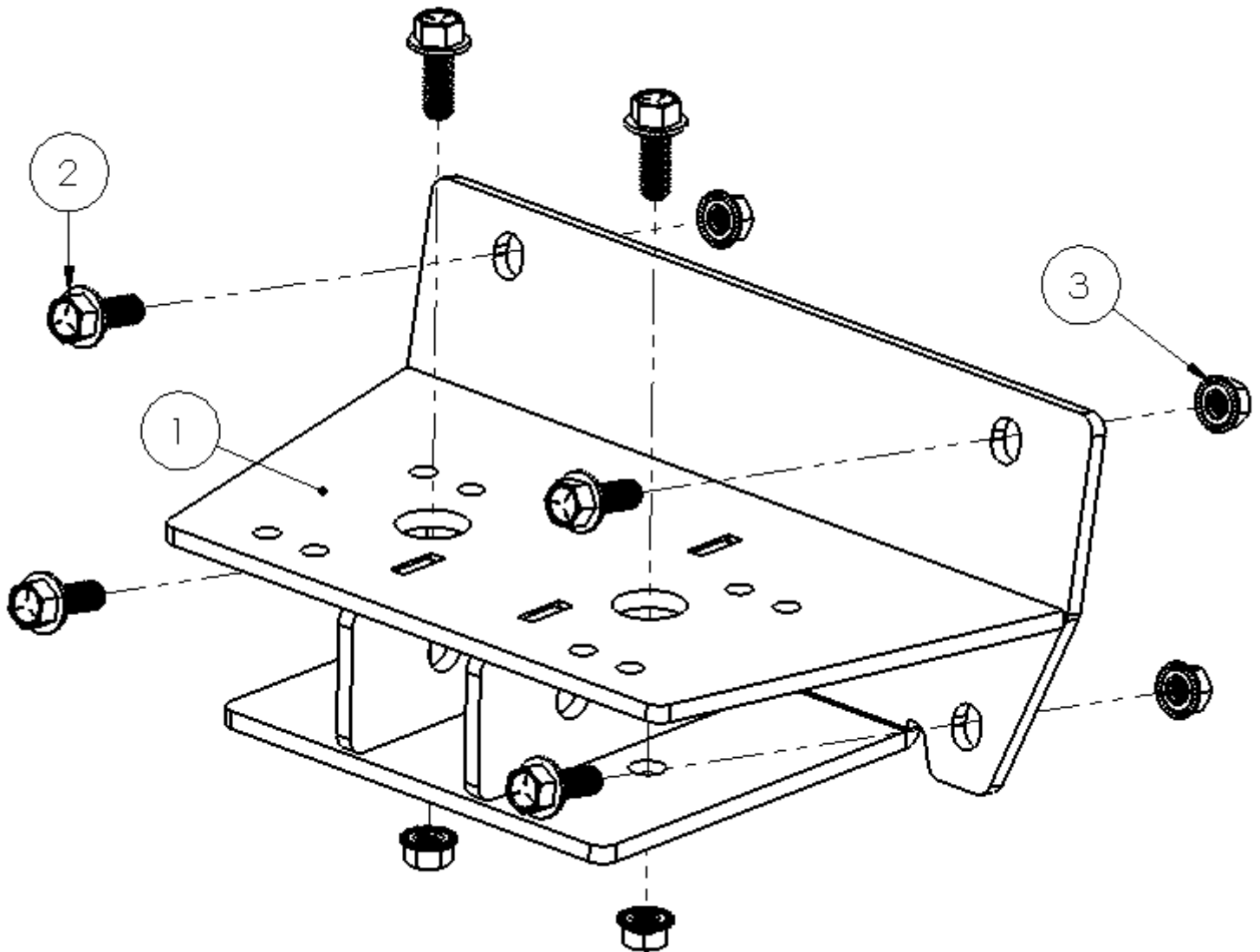

**MA11991 Winch Mount Assembly View**

- 1) If the winch includes a Rubber Line Stopper, remove the steel cable or synthetic rope from the winch. Pass the cable through the Rubber Line Stopper and then through the Roller Fairlead or Aluminum Hawse. Leave the cable unattached at this point. After the winch is fully installed, reattach the cable to the winch. Leave the cable unwound as it will be wound under load to properly set the cable. See Figure 1.

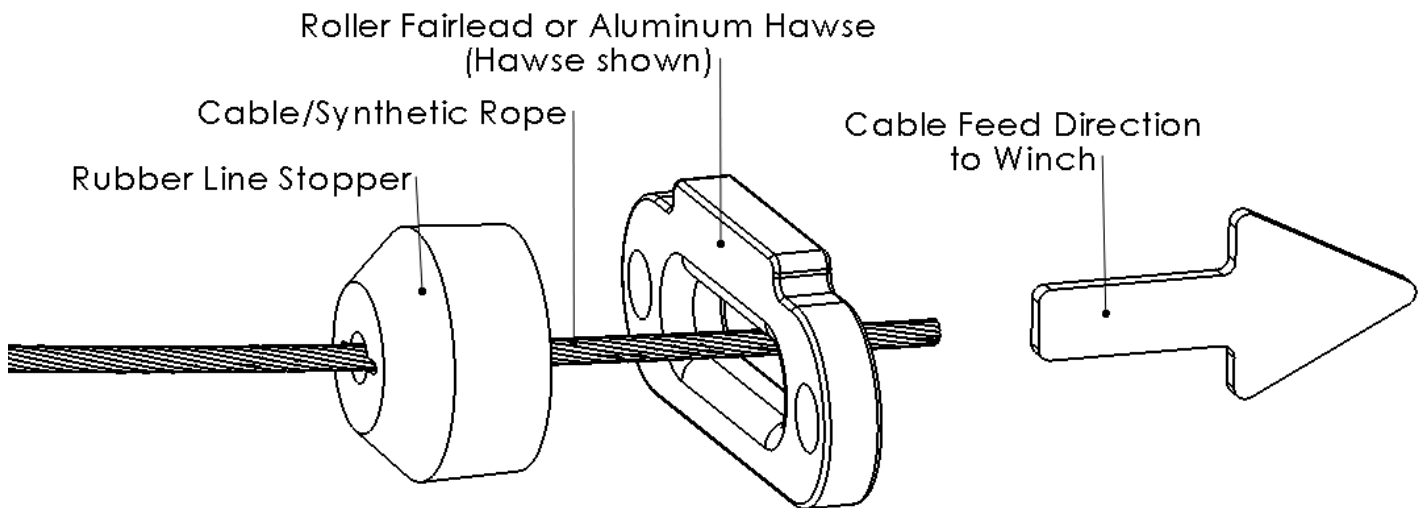

**Figure 1**

- 2) Attach the winch's fairlead (Roller or Hawse) to the Universal Fairlead Mount included in all VIPER winch kits using the hardware supplied in the winch kit. See Figure 2.

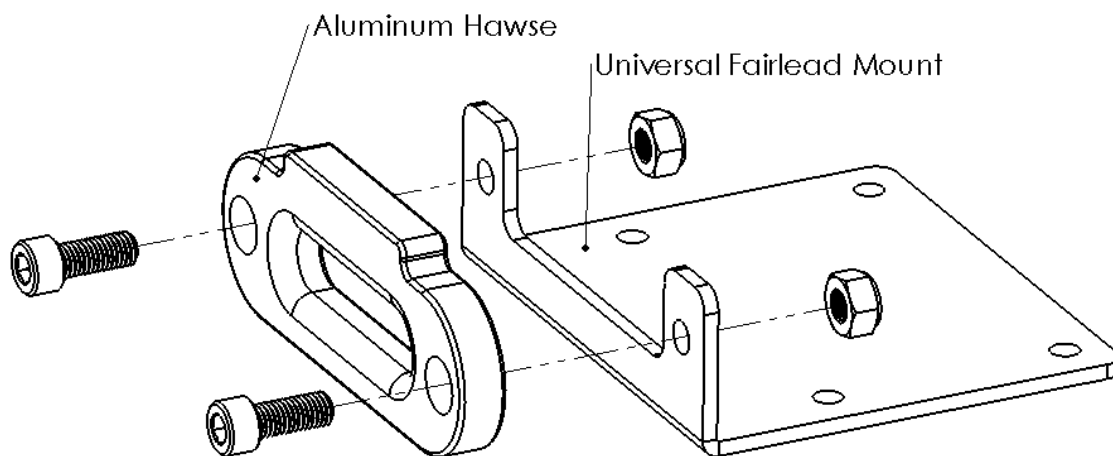

**Figure 2**

**MA11991  
John Deere RSX 850i Winch Mount**



**motoalliance**

23001 Industrial Blvd  
Rogers, MN 55374  
866.527.7637

- 3) Remove the black front bumper and plastic front fascia (bumper appearance may vary from 850i, 850i Trail and 850i Sport models) until the winch mounting location is accessible as shown in Figure 3.



**Figure 3**

- 4) Use the six (6) 3/8 x 1" Serrated Flange Bolts and six (6) 3/8" Serrated Flange Nuts to secure the MA11991 Winch Mount to the frame. See Figure 4 and 5.  
**Installation Tip:** Use a socket extension to tighten the two bolts that connect to the silver bumper bracket.

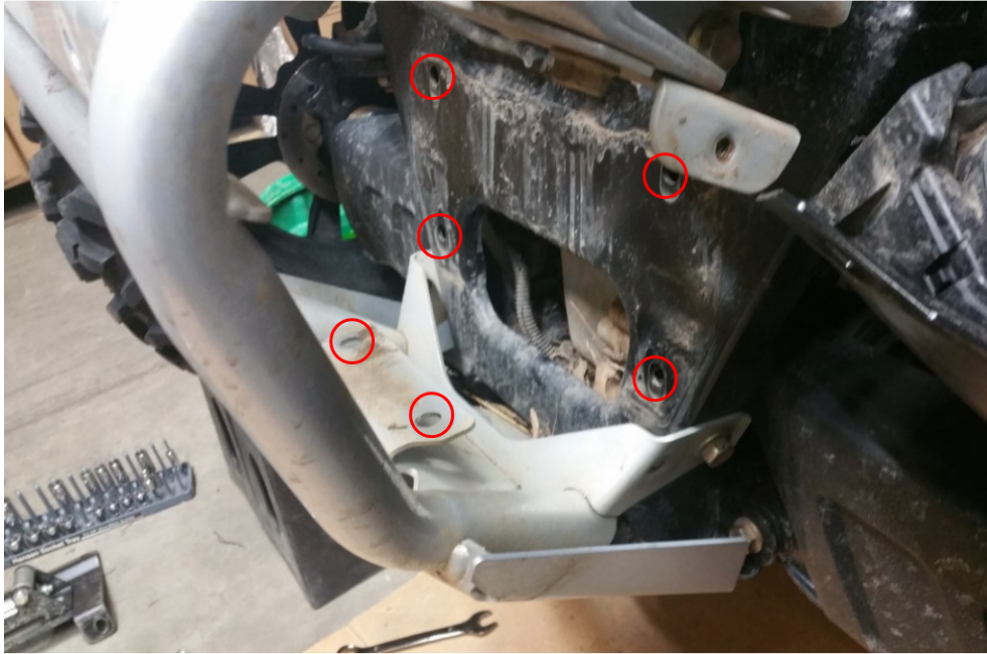

Figure 4

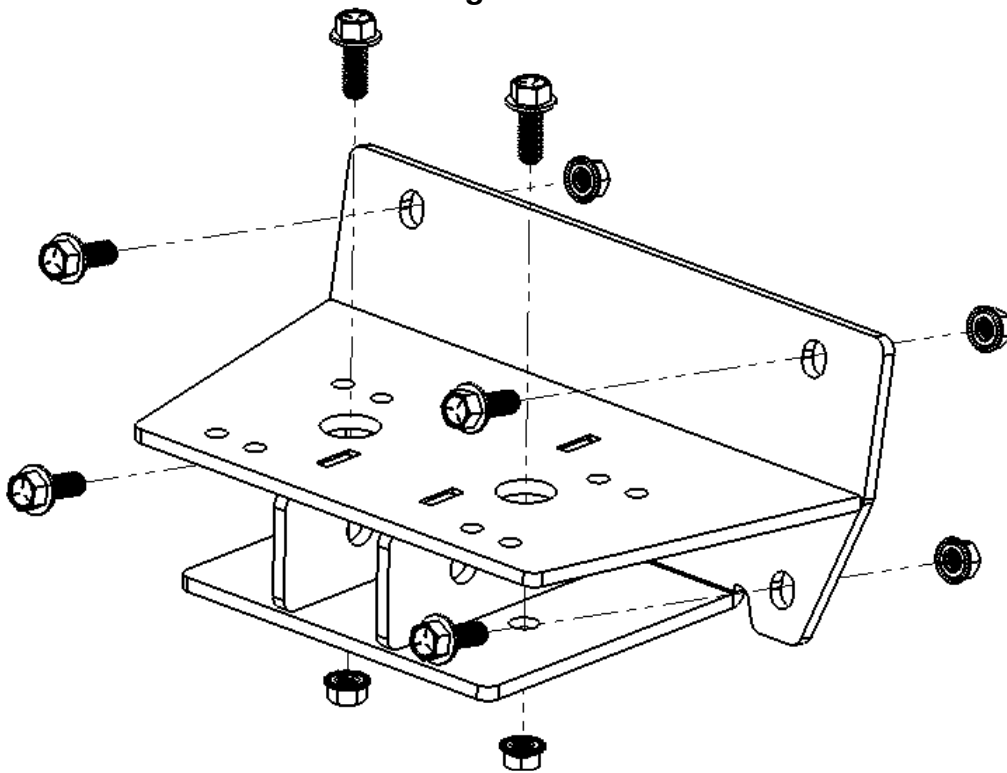

Figure 5

**MA11991  
John Deere RSX 850i Winch Mount**



**motoalliance**

23001 Industrial Blvd  
Rogers, MN 55374  
866.527.7637

- 5) Place the Universal Fairlead Mount (shown in Figure 2) on top of the MA11991 Winch Mount. Position the winch over the same holes and use the M8-1.25 x 25mm Hex Bolts included in the winch kit to secure the winch to the winch mount plate. See Figure 6 (winch not shown).

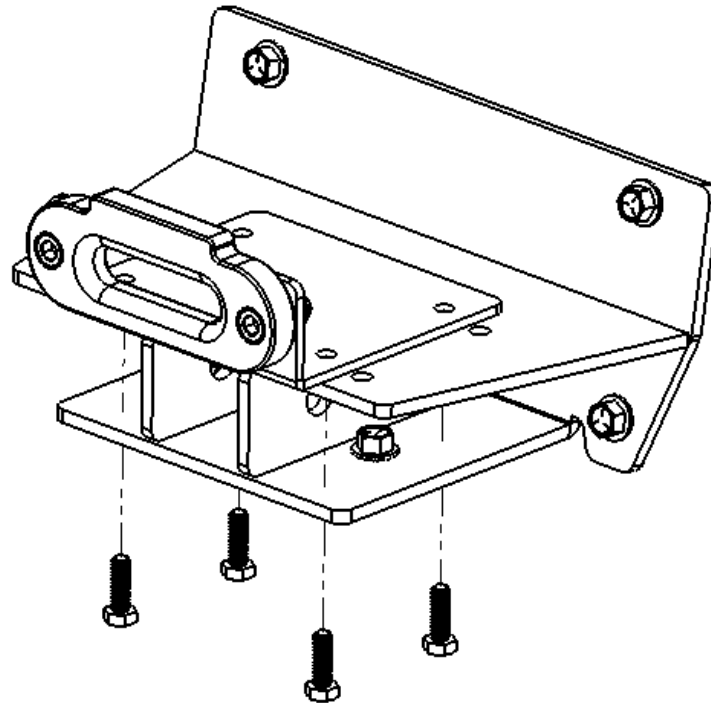

**Figure 6**

- 6) Check and tighten all hardware.
- 7) Reattach the winch cable to the winch.
- 8) Reinstall the bumper and hardware in reverse order.
- 9) Mount the contactor under the hood of the machine and wire up according to the winch manual. It may be necessary to swap the longer blue and yellow wires with the shorter black and red wires on some winches.
- 10) Once the winch is wired up properly, tie the end of the cable off to a secure location (such as a tree, a post, or a full sized truck), set the brake on your machine and wind the winch in carefully, watching to make sure the cable doesn't become tangled. This will help set the cable and prevent future tangles.